



REFLEX™ PROJECTION SCREEN

→ INTRODUCTION

> To answer the growing demand for a product to deliver the ultimate in home theatre visual experience, **REFLEX™** has designed and developed the **REFLEX™ PROJECTION SCREEN** range with a great degree of versatility to adapt to the many and varied theatre situations such as office presentations, residential theatres and small to mid sized conference facilities.

As with most **REFLEX™** products, the **PS95** incorporates the very latest in motorisation technology for ease of integration with operating and control systems to deliver the ultimate in convenience. The screen material can be either the standard gain (1:1) Matte White finish for broad viewing (suggested for home theatres where a wide viewing angle may be up to 150°—160°) or the high gain (up to 2.5:1) “Nanolens” screen for the very best in viewing where indirect/tangential lighting may be a problem and a viewing angle less than the Matte White is acceptable.

APPLICATION

> Consideration should be given to the following criteria in selecting the best screen for each application:

- Desired format (this may be fixed or variable depending on the projector and source);
- Projector to screen distance and desired image size;
- Screen surface can be either standard Matte White finish or the high gain Nanolens where maximum gain is desired or ambient tangential light is a problem and a narrower viewing angle is satisfactory.

The Aluminium **REFLEX™ RPS** cassette is ideally suited to internal installation as either “face” fix (onto vertical walls) or “top” fix (to the ceiling or within a recess).

The mounting of the cassette is simplified through the implementation of the supplied fixing brackets.

SPECIFICATIONS

> The head box shall be a pair of 6106 aluminium alloy extrusions and is comprised of:

1. A main mounting rail which has various fixing facilities and positioning for the substrate fixings;
2. The detachable fascia which shall snap onto the main rail to completely cover the system;
3. The end plates which shall be glass reinforced, UV stabilised nylon with facilities to receive the screen hardware attachment.
4. 60 mm aluminium roller with associated hardware to support the screen fabric without deflection.
5. Screen fabric of coated and stabilised polyester with the selected finish to the front.
6. Black powder coated hem rail (to suit).
7. Molex inline electrical connector and tail at 1,000 mm to suit.
8. Infra-red, radio frequency or hard wire connections to suit control system requirements.

Sizes:

Video	4:3	70" 80" 100" 120"
Widescreen	16:9	80" 90" 100" 110"

REFLEX™ PROJECTION SCREEN

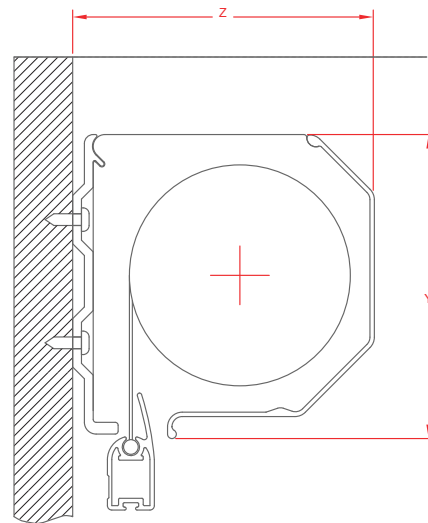
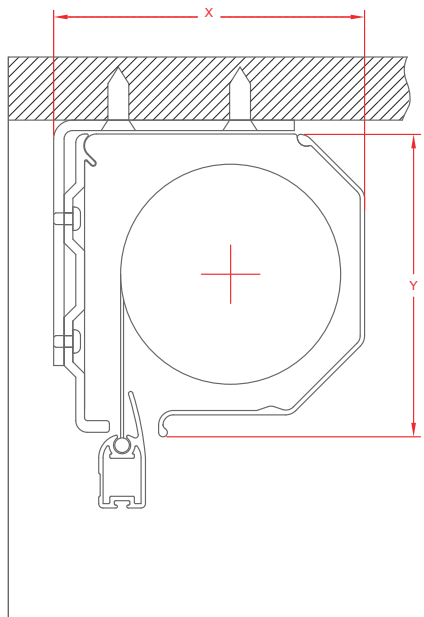

	PS95
X =	106
Y =	105
Z =	103

TOP FIX ARRANGEMENT

FACE FIX ARRANGEMENT

REFLEX™ PROJECTION SCREEN EXPLODED

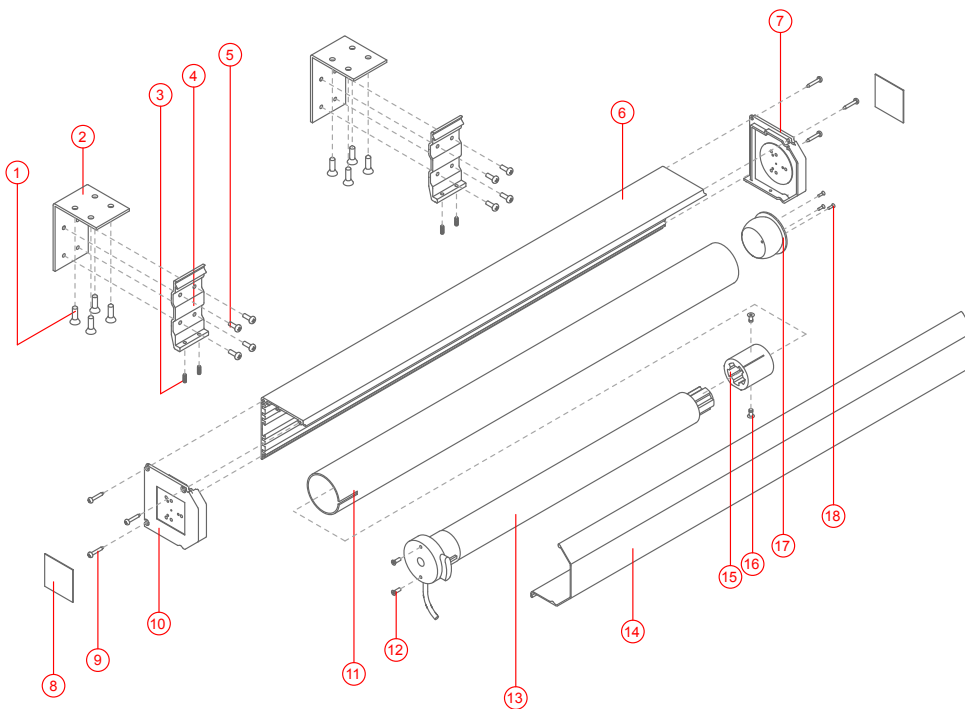

ITEM	DESCRIPTION
1.	MOUNTING SCREWS
2.	MOUNTING BRACKET
3.	BACK BRACKET GRUB SCREW
4.	BACK BRACKET
5.	BRACKET MOUNTING SCREW
6.	HEADBOX COVER - BACK
7.	END COVER - RHS
8.	END COVER - INFILL
9.	END COVER SCREW
10.	END COVER - LHS
11.	ROLLER TUBE
12.	MOTOR FIXING SCREWS
13.	MOTOR
14.	HEADBOX COVER - FRONT
15.	MOTOR WHEEL
16.	RIVET
17.	BEARING
18.	BEARING SCREW